

# INTEGRA *vac*

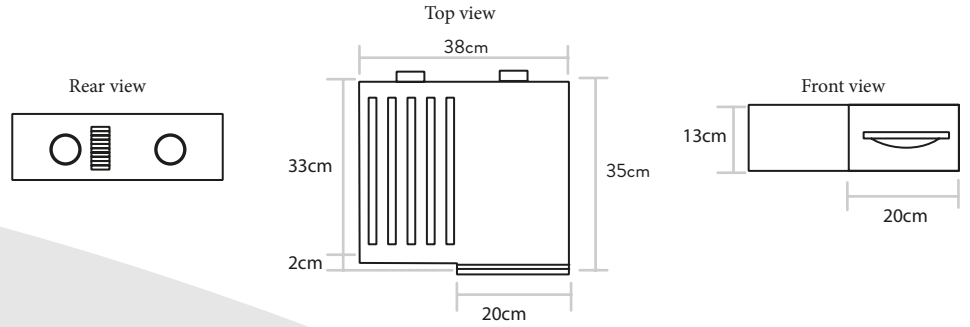

POWER	1400
AIR FLOW (M <sup>3</sup> )	187
WATER LIFT (MM/H <sub>2</sub> O)	2850
AIRWATTS	532
DUSTBAG CAPACITY (L)	4
WEIGHT (KG)	8
NOISE LEVEL (DB)	≤ 60
HIGH-SPEED THRU-FLOW MOTOR	

## TECHNICAL DETAILS

### RECOMMENDATIONS FOR INSTALLATIONS

MAXIMUM HOME SIZE IN M <sup>2</sup>	≤ 250
MAXIMUM DISTANCE FROM THE MOST DISTANT VALVE (L.M.)	30
MAXIMUM NUMBER OF INLET VALVES	5

[WWW.INTEGRAVAC.COM](http://WWW.INTEGRAVAC.COM)